



# Elfin — 10-L Collaborative Robot

## Core Parameters

Model	E10-L
Weight	45kg
Payload	8kg
Reach	1300mm
Joint range	±360°
Tool speed	2m/s
Repeatability	±0.03mm

## Basic Parameters

Model	E10-L
Power consumption	350W typical application
Joint speed	J1-J2 100°/s J3-J4 150°/s J5-J6 180°/s
Degree of freedom	6
End I/O port	Digital input: 3, digital output: 3, analog input: 2
Control box I/O port	Digital input: 16, digital output: 16, analog input: 2, analog output: 2
I/O Source	24V 2A
Communication	TCP/IP and Modbus
Programming	Graphical programming, remote call interface
IP classification	IP54
Collaborative operation	10 advanced security configuration functions
Main material	Aluminum alloy
Working temperature	0-50°C
Power input	200-240V AC, 50-60Hz
Cable	Cable to the control box: 5m; cable to the teach pendant: 5m

## Size Specification

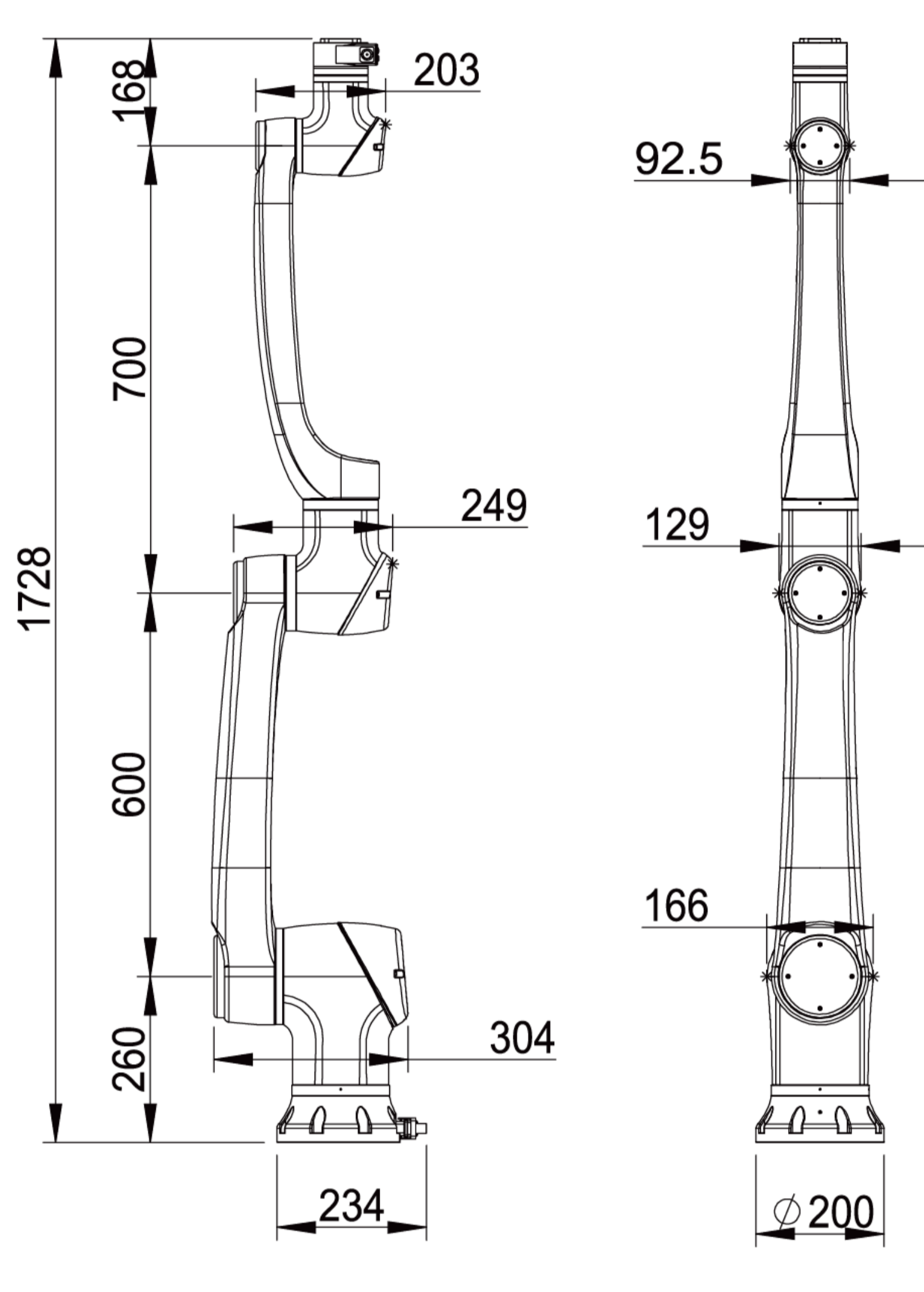

Elfin — 10-L Size Specification

## Installation Size

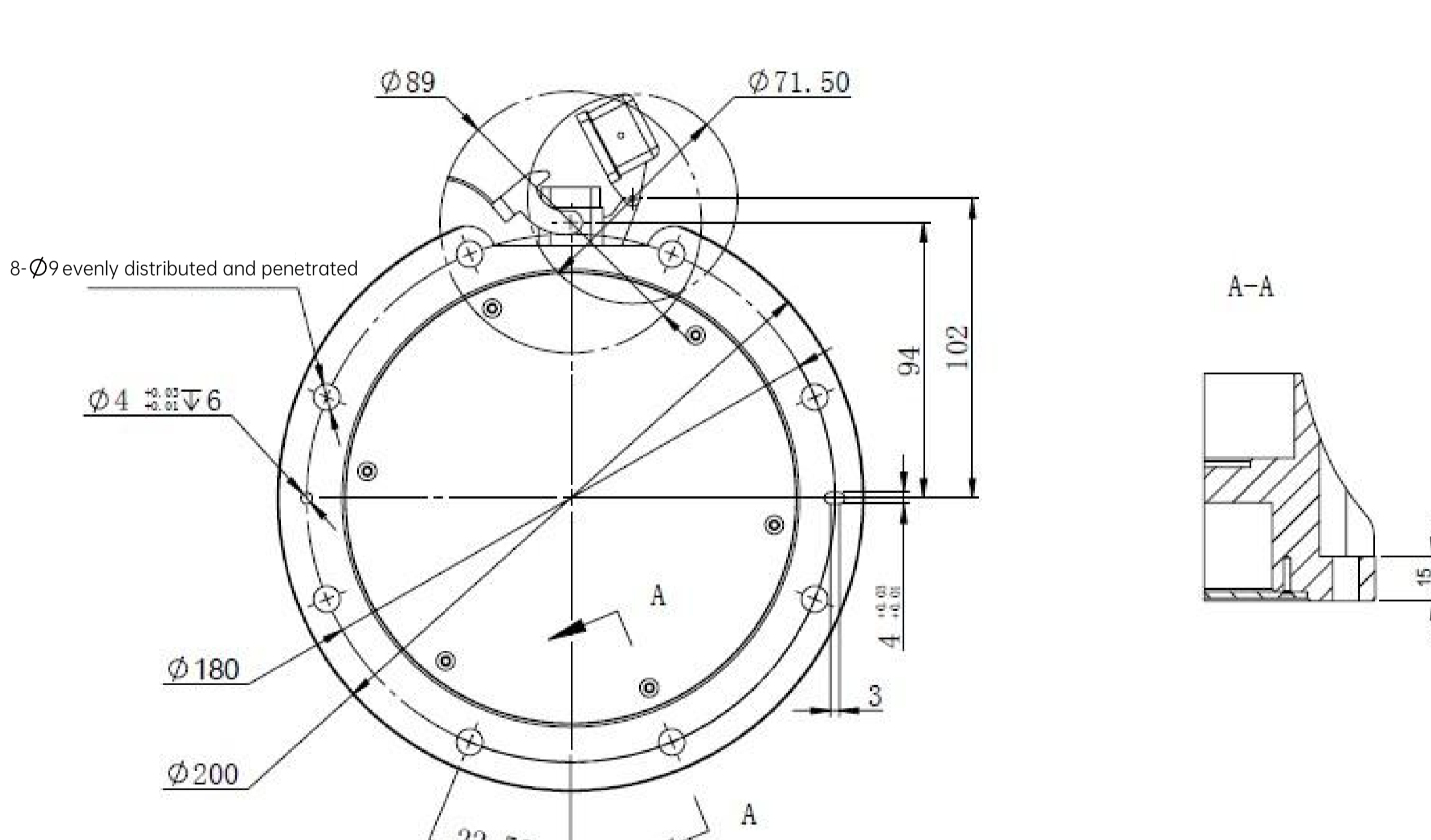

Elfin — 10-L Base Installation Size

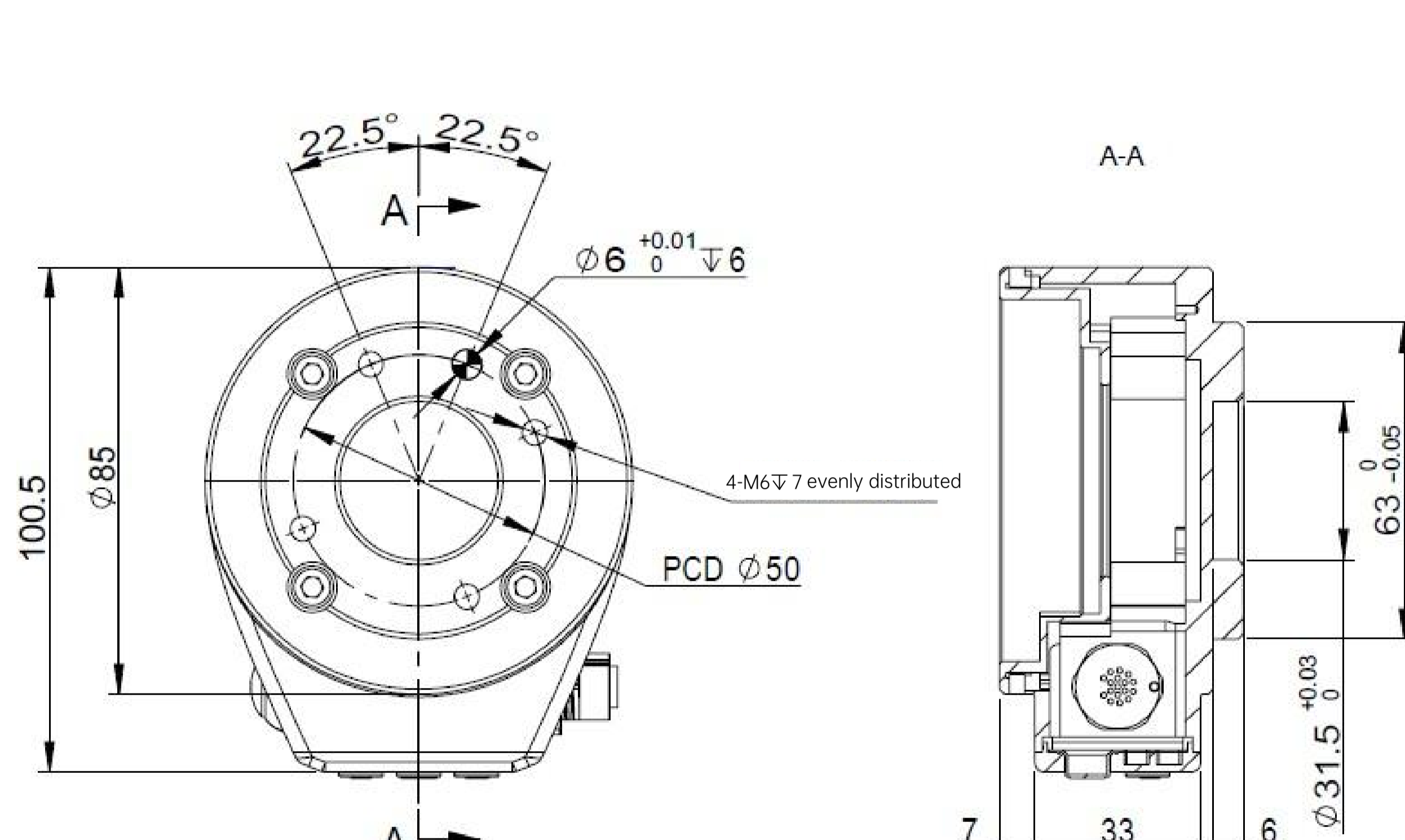

Elfin — 10-L End Installation Size

## Control box



### Control box(standard)

Dimensions	445.2mm x 318.8mm x (360+176)mm
Stand height	176mm
Weight	18.5kg
Power output	48V DC
Working temperature	0~50°C
Working Humidity	90% relative humidity (non-condensing)
IP classification	IP20

### Mini Control Box (Optional)

Dimensions	323x221x80(mm)
Power Input	DC30~60V
I/O Source	DC24V
I/O Port	Inputs 8 , Outputs 8
IP Classification	IP20
Communication	TCP/IP Modbus

